

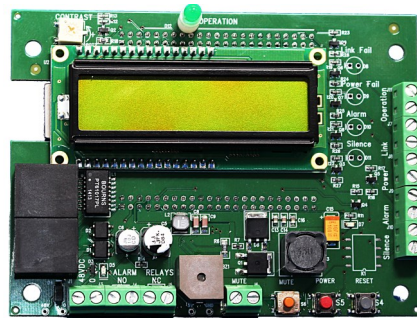

# WAM-301 IP ALARM MODULE

## FEATURES AND BENEFITS



WAM-301-00

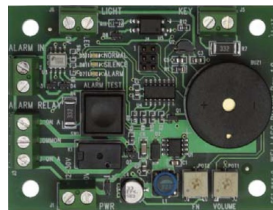

LA-SC

- Audible indication of fault conditions
- Optional LCD display to report specific conditions
- Fully configurable to provide alert for any Fire Recall group
- Exceeds CSA B44 2013 line operability requirements
- Key switch to silence audible alarms
- Amplified with AC power
- Equipped with self-diagnostics
- Simple local or remote programmability
- Maintenance free
- POE powered

### SCALABLE MONITORING

With the addition of LA-SC boards the WAM provides LED and buzzer monitoring of up to 6 individual banks. Additional banks can be monitored with the by adding an additional WAM-301. Unlimited banks can be monitored with the Webb Safe system.

### TYPICAL APPLICATIONS

Fire Recall Areas,  
Areas of Rescue,  
Elevator Lobbies,  
Security Stations,  
And Transportation Help Stations.

**Description:** The WAM-301 is an IP Alarm Module providing visual and audible indication of emergency phone status. Designed for use with the WEBB Safe-300 IP System, the WAM-301 integrates seamlessly via ethernet connection.

## Ordering Information

WAM-301-00	LCD Alert Module	6.5"W x 4"H x 2"D Unhoused including cross connect cable
WAM-311-00	LCD Alert Module	8.5"W x 4.5"H x 3.5"D Housed with brushed stainless steel faceplate
WAM-302-00	Basic Alert Module	6.5"W x 4.5"H x 3.5"D Unhoused including cross connect cable
WAM-312-00	Basic Alert Module	8.5"W x 4.5"H x 3.5"D Housed with brushed stainless steel faceplate



# WAM-301 IP ALARM MODULE

## Specification:

<b>Power:</b>	48V DC Power over Ethernet (POE)
<b>Communication:</b>	Proprietary protocols over Ethernet
<b>Buzzer:</b>	80dB at 3m
<b>Output:</b>	1 NO or NC dry contact, 5 Open collector outputs
<b>Visual Indicators:</b>	Operation, Power, Link-fail, Alarm, Mute
<b>Display (Optional):</b>	2x16 Character LCD
<b>Temperature:</b>	0 - 60°C
<b>Certification/ Compliance:</b>	ADA, FCC - Part 68, Industry Canada, ASME A17.1, CSA B44
<b>Shipping Weight:</b>	3.8lb, 1.7Kg
<b>Warranty:</b>	2 years from date of purchase.

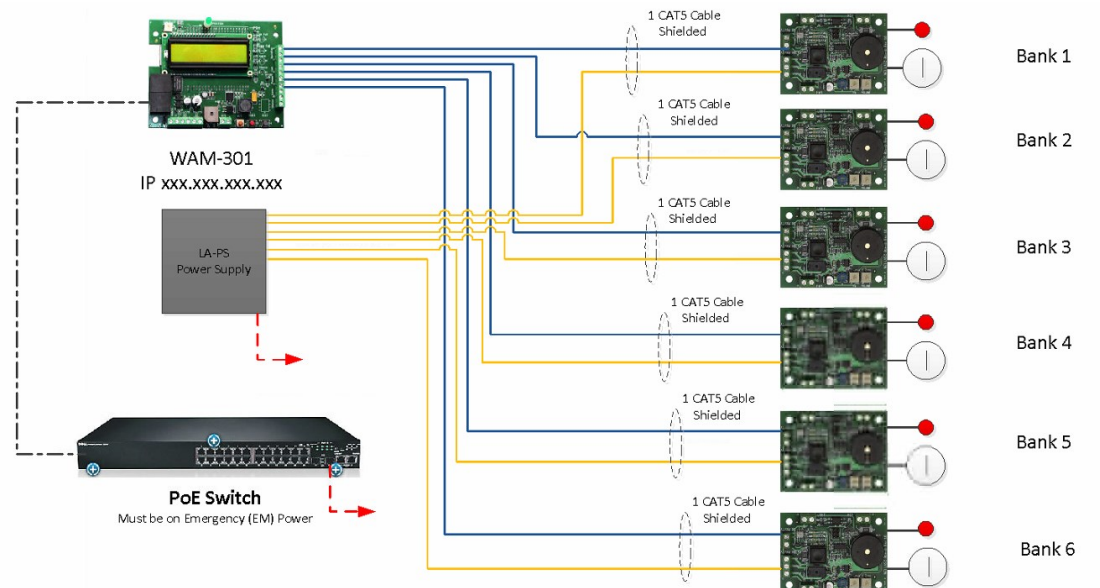

## Legend

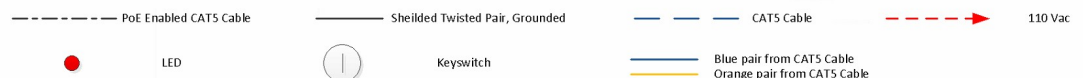

Supplied and serviced by:

*information may change without notice*



Member of the CIS Group of Companies  
 Vancouver • Toronto • Montreal • Florida  
 1-877-731-1010  
 info@webbelectronicinc.com  
[www.webbelectronicinc.com](http://www.webbelectronicinc.com)